

Eclipse ThermJet

Burners

Model TJ0050
Version 2

| PARAMETER | BURNER VELOCITY | MODEL TJ 0050 |
|--|--|--|
| Maximum input Btu/hr (kW) | Medium & High Velocity | 500,000 (146.5) |
| Minimum Input, on-ratio Btu/hr (kW) | Medium & High Velocity | 50,000 (14.6) |
| Minimum Input, fixed air Btu/hr (kW) | Medium & High Velocity | 10,000 (2.9) |
| Gas inlet pressure required "w.c. (mbar) • Fuel pressure at gas inlet (Tap "B" – see page 3) | High Velocity | Nat. Gas Propane Butane 16.2 (40.3) 19.6 (48.8) 17.1 (42.6) |
| | Medium Velocity | Nat. Gas Propane Butane 8.9 (22.2) 11.4 (28.4) 9.6 (23.9) |
| Air inlet pressure required "w.c (mbar) • 15% excess air at maximum input (Tap "A" – see page 3) | High Velocity | Nat. Gas Propane Butane 16.7 (41.6) 18.0 (44.8) 17.4 (43.3) |
| | Medium Velocity | Nat. Gas Propane Butane 9.9 (24.6) 10.9 (27.1) 10.5 (26.1) |
| High Fire Flame Length Inches (mm) (measured from end of combustor) | High Velocity | Nat. Gas Propane Butane 25 (635) 33 (838) 30 (762) |
| | Medium Velocity | Nat. Gas Propane Butane 28 (711) 36 (914) 39 (991) |
| Maximum flame velocity ft/s (m/s) • 15% excess air, at maximum input | High Velocity | 500 (152.4) |
| | Medium Velocity | 250 (76.2) |
| Maximum combustion air temperature | 300° F (149 °C) For higher temperatures, use TJPCA (Data 206) | |
| Flame detection | U.V. scanner available for all combustors. Flame Rod available for use with alloy or silicon carbide combustors only. | |
| Fuel | Natural Gas, Propane, Butane For any other mixed gas, contact Eclipse for orifice sizing. | |

- All information is based on laboratory testing in neutral (0.0" w.c.) pressure chamber. Different chamber size and conditions may affect the data.
- All information is based on standard combustor design. Changes in the combustor will alter performance and pressures.
- All inputs based upon gross calorific values.
- Eclipse reserves the right to change the construction and/or configuration of our products at any time without being obliged to adjust earlier supplies accordingly.
- Plumbing of air and gas will affect accuracy of orifice readings. All information is based on generally acceptable air and gas piping practices.
- Do not install the burner with the gas inlet rotated 90° clockwise with respect to the air inlet if operating on natural gas using a flame rod.

Performance Graphs

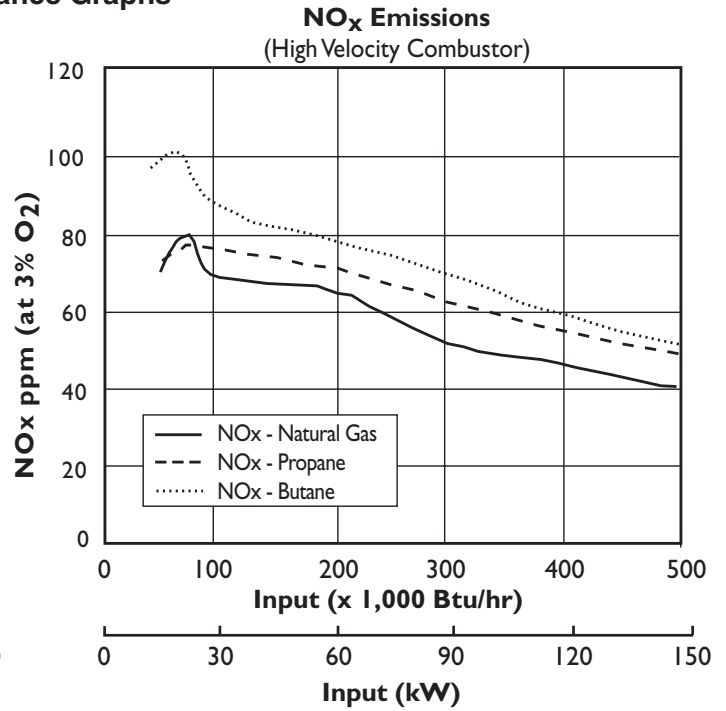
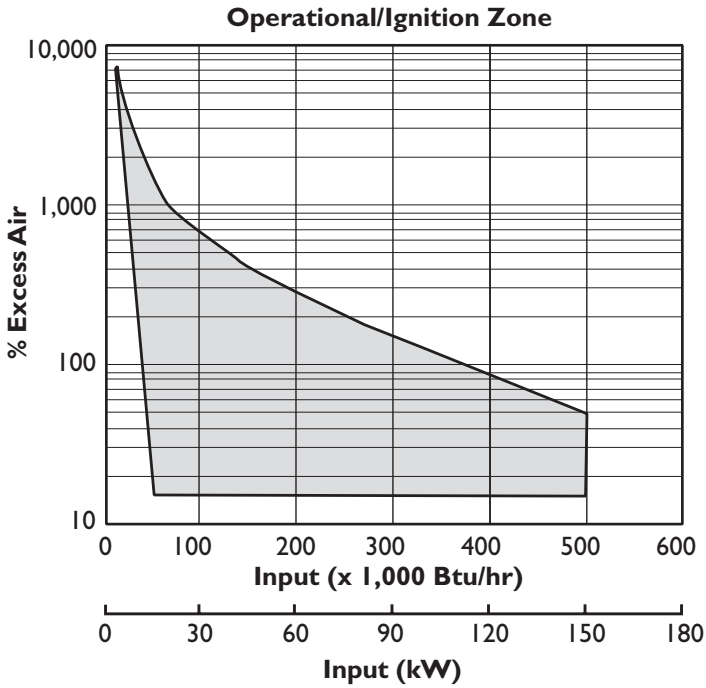

Correction factor for medium velocity combustor is 1.20
 On Ratio: Combustion air is adjusted to 3% O₂ at any given input.

Emissions from the burner are influenced by:

- fuel type
- combustion air temperature
- firing rate
- chamber conditions
- percent of excess air

For estimates of other emissions, contact Eclipse.

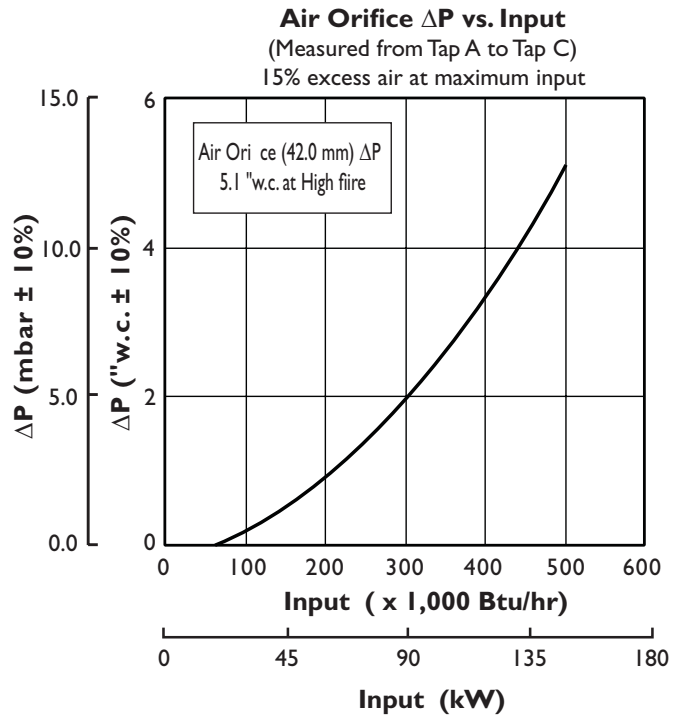
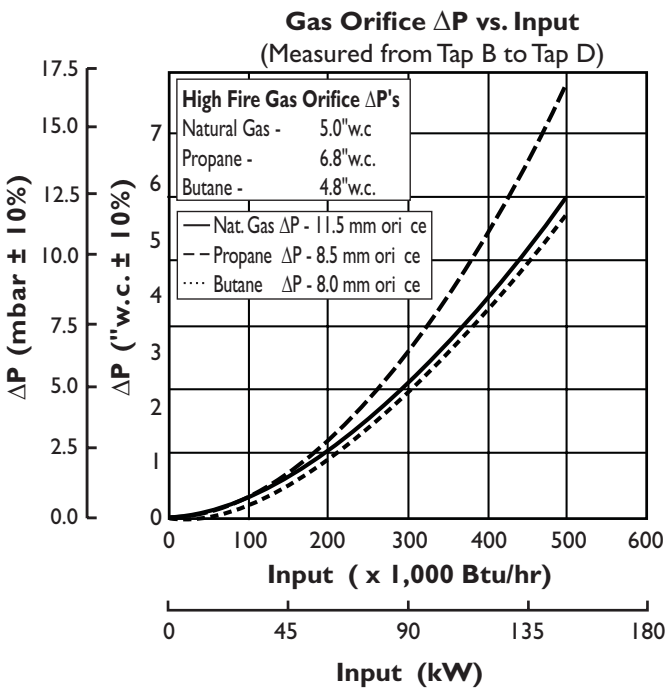

Dimensions & Specifications Millimeters (Inches)

Burner Housing

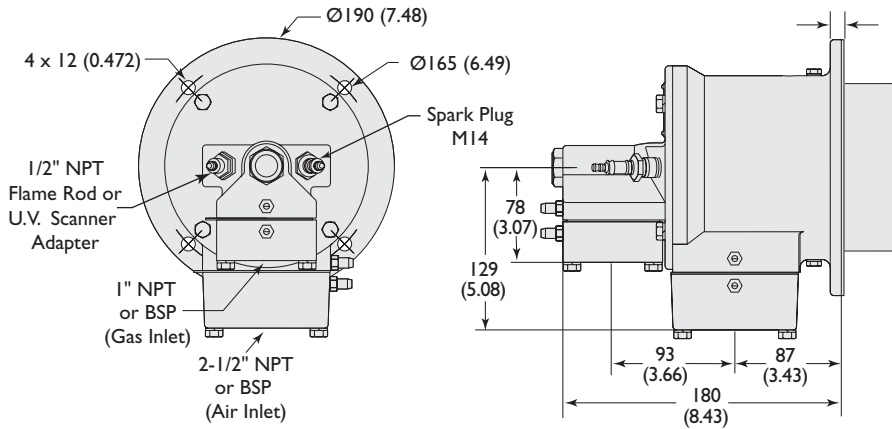

Burner weight less combustor: 37 lb (17 kg)

Tap Locations

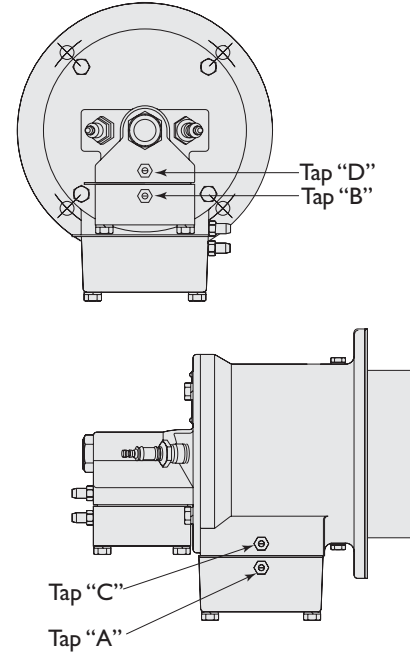

Combustor

Exhaust outlet diameter : Medium Velocity : $\text{Ø}53.5$ (2.11)
High Velocity : $\text{Ø}41$ (1.61)

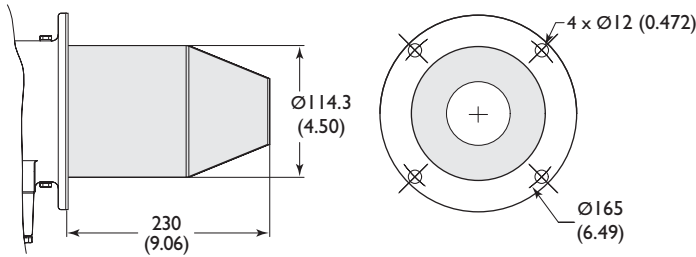

Alloy Tube (AISI 10)

Weight: 3.0 lb (1.36 kg)
Max Chamber Temp: 1,750°F (950°C)

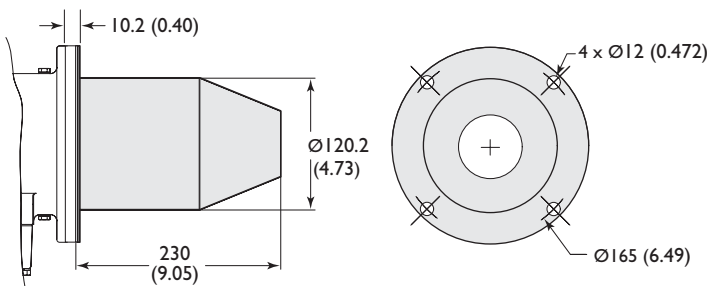

Silicon Carbide Tube

Weight: 3.3 lb (1.5 kg)
Max Chamber Temp: 2,500°F (1371°C)

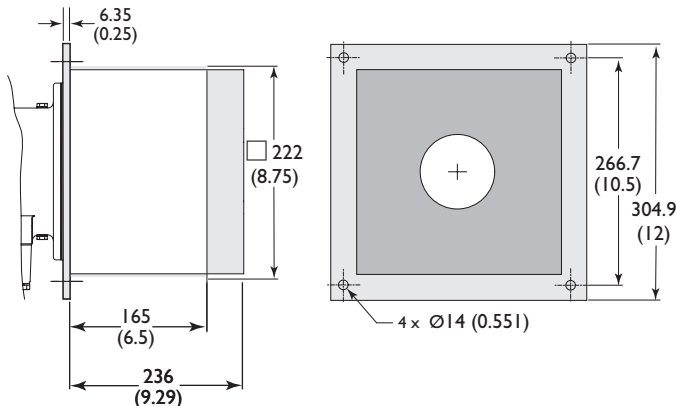

Refractory Block (w/RA330 wrapper)

Weight: 62.5 lb (28.3 kg)
Max Chamber Temp: 2,800°F (1538°C)

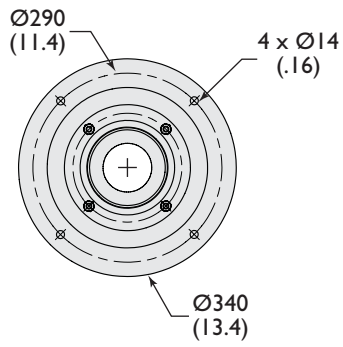
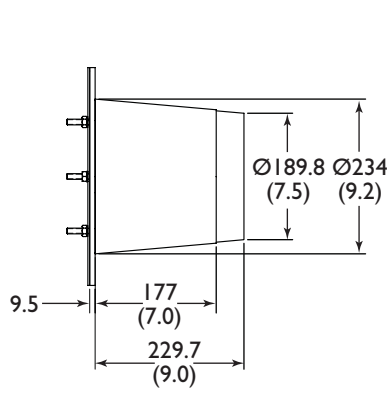

Down Firing Block
 Weight: 60 lb (27.22 kg)
 Max. Chamber Temp: 2800°F (1535°C)



Offered By:

Power Equipment Company
2011 Williamsburg Road
Richmond, Virginia 23231
Phone (804) 236-3800
Fax (804) 236-3882

www.peconet.com